



Operating Manual of  
GY46X/GY56X/GY86X  
GY46X-300/GY56X-300/GY86X-300  
Connecting  
Cone Through Type Deluge Alarm  
Valve

Ningjin APC Industries Incorporated Company

No.18 Taishan Road,Ningjin County,Shandong Province,China,P.R.253418

[www.apc-valve.com](http://www.apc-valve.com)

Tel:+86-534-5571078

Fax:+86-534-7076242

**Foreword**

Please be sure to read this manual carefully before using this product to understand its structural performance, usage and relevant regulations of the company. All losses caused by the failure or damage of this product due to improper installation or operation of the product, or the failure not to use, maintain and repair the product following this manual will have nothing to do with the company, and the company will not bear any consequences incurred.

Ningjin APC Industries Incorporated Company. will constantly improve the product, so structure or performance of products manufactured subsequently may change without prior notice. Please do not use the manual of other versions as the reference of the structure or characteristics of your product, and any requirements for modification or supplement of equipment based on the difference between the two manuals will not be accepted. Please consult our after-sales service department in case of any questions about your product and the manual. Please keep the manuals properly.

## CONTENT

1. Overview .....	1
1.1 Main application and scope of application .....	1
1.2 Models .....	1
1.3 External loop .....	2
2. Safety Precautions .....	3
3. Structural Characteristics and Operating Principle .....	3
3.1 Operating principle .....	3
3.2 Structural characteristics .....	4
4. Technical characteristics .....	7
5. Size .....	9
6. Installation and Commissioning .....	9
7. Usage and operation .....	11
8. Fault Analysis and Troubleshooting .....	11
9. Safety Protection Device and Trouble Removal .....	12
10. Maintenance and Repair .....	13
10.1 System periodic tes .....	13
10.1.1 Alarm test .....	13
10.1.2 Manual switch function test .....	13
10.1.3 Remote switch function test .....	14
10.2 System periodic maintenance .....	14
10.2.1 Diaphragm chamber .....	14
10.2.2 Reset valve examination .....	15
10.2.3 Drip valve examination .....	15
10.2.4 Pressure gauge examination .....	15
10.2.5 Filter and pipeline inspection .....	15
10.3 Specific Record .....	15
11. Transportation and Storage .....	16
12. Unpacking and Check .....	16
13. Environmental Protection and Others .....	16
13.1 Important safety information .....	16
13.2 Environmental control .....	17

## 1. Overview

### 1.1 Main application and scope of application

GY46X/GY56X/GY86X/GY46X-300/GY56X-300/GY86X-300 deluge alarm valve adopts the Straight-through cone diaphragm seal, using the good self-sealing of the cone to open and close the valve. The pressure in the diaphragm chamber is released by electric, pneumatic or manual methods, the valve disc opens automatically so that the water can flow into the sprinkler system in one direction automatically and alarm at the same time. It can also form a variety of deluge alarm and firefighting systems with other components. It is suitable for automatic sprinkler systems installed in places such as residential houses, hospitals, hotels, shopping malls, factories, airports, casinos, libraries, stadiums, convention and exhibition centers. The operating ambient temperature shall not be lower than 4°C and not higher than 52°C.

### 1.2 Models

GY46X -----Flanged\*Flanged Connection  
GY56X-----Flanged\*Grooved Connection  
GY86X-----Grooved\*Grooved Connection  
GY46X-300 -----Flanged\*Flanged Connection  
GY56X-300-----Flanged\*Grooved Connection  
GY86X-300-----Grooved\*Grooved Connection

## 1.3 External loop

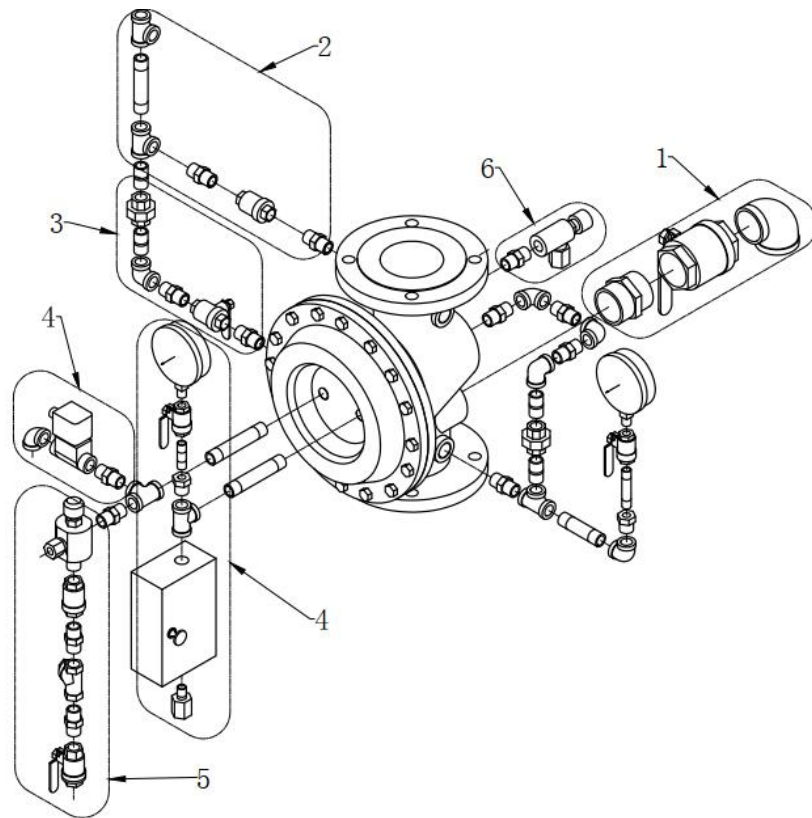

**1.3.1 Drainage loop 1.** It is used to drain the water above the valve Disc in the valve body and the pipeline behind the valve out of the valve after the deluge alarm valve is reset for the primary use, and the drain ball valve shall be closed after the water is completely drained (this drain ball valve is normally closed and can only be switched on during water drainage). For 2" valves, the drain ball valve is 3/4", 2\*1/2"-3" valves, the drain ball valve is 1\*1/4" and 4"-8" valves, the drain ball valve is 2".

**1.3.2 Alarm loop 2.** The water enters the alarm bell and pressure switch or other alarm devices through the alarm loop when the deluge alarm valve actuates. The reserved alarm system interface is 3/4".

**1.3.3 Alarm test loop 3.** This loop is used to conduct the periodic reliability test of the alarm system when the deluge alarm valve is in a servo state. During the test, switch on the ball valve on the circuit (this ball valve can only be switched on during the test) and water enters the alarm system from the water supply side of the valve Disc; and close the test ball valve in time when the test is completed.

**1.3.4 Release loop 4.** It is connected to the diaphragm chamber and used for release the pressure in it. It can be divided into automatic release and manual emergency release. The

automatic release can be connected to solenoid valve or pneumatic actuator.

**1.3.5 Water injection loop 5.** It is used to inject water in the diaphragm chamber to finish the valve reset. **This loop must be connected to the water supply side of the water supply control valve in front of the alarm valve.**

**1.3.6 Automatic drainage loop 6.** After the valve reset drainage, residual water above the valve Disc or tiny amount of water leaked through the valve is drained through this loop out of the valve.

## **2. Safety Precautions**

**2.1** The deluge alarm valve will have a long service life as long as it is used and maintained properly. Please be sure to perform regular repair and maintenance during use to ensure the proper overall performance and safety of the deluge alarm valve.

**2.2** After the deluge alarm valve being installed and commissioned, please make sure the max rated operating pressure 250/300PSI to avoid leakage or parts damage.

**2.3** When the deluge alarm valve bank is in a ready condition, the alarm system shall be on. If the alarm system is switched off, the deluge alarm valve works normally, and there is no water in the alarm pipeline, then the alarm bell in the alarm system will not alarm, and the pressure switch will not work.

**2.4** In the case of improper installation and use of the deluge alarm valve, the product and its functional parts may cause potential safety hazards and may result in personal injuries and property losses. In order to reduce these hazards, please strictly follow the relevant standards and specifications in terms of installation, use, operation, and maintenance, and follow all the reminding information on the manual and the product.

**2.5** The valve assembly will not configured with wet pilot sprinkler line.

## **3. Structural Characteristics and Operating Principle**

### **3.1 Operating principle**

**3.1.1** Switch on. In case of a fire, the fire signal is transmitted to the control center, and the

control center processes the signal and sends a switch-on signal to the solenoid valve or pneumatic actuator on the release loop of the deluge alarm valve. The solenoid valve or pneumatic is switched on, and the diaphragm chamber releases pressure, thus switching on the deluge alarm valve. Water enters the system pipe network from the water supply side, and is sprinkled to the entire protection area through nozzles to perform the firefighting function. When the solenoid valve or pneumatic actuator cannot be switched on normally after receiving the signal, the operator shall switch on the manual emergency release valve to relieve the pressure in the diaphragm chamber.

**3.1.2 Reset.** After the fire is extinguished, switch off the solenoid valve or pneumatic actuator on the release loop, the manual emergency release valve, and the water supply control valve in front of the alarm valve. Then the operator presses the manual reset valve on the water injection loop to quickly inject the diaphragm chamber with water, and the deluge alarm valve will be reset. Release the manual reset valve when the water pressure in the diaphragm chamber and the water supply side are the same. At this time, the one-way valve in the manual reset valve is automatically switched on to keep the pressure in the diaphragm chamber and the water supply side consistent. Finally, switch on the water supply control valve in front of the alarm valve to complete the reset.

**3.1.3 Anti-reset.** The manual reset valve on the water injection loop of the alarm valve is equipped with the automatic drainage and anti-reset device. When the pressure in the diaphragm chamber is released, the pressure difference between the water supply side and the diaphragm chamber will automatically switch on the one-way valve in the reset valve, and water cannot enter the diaphragm chamber anymore. At the same time, the drain channel in the reset valve is opened. At this time, the diaphragm chamber is still connected to the atmosphere even if the solenoid valve or pneumatic actuator on the release loop fails for some reasons, thereby preventing the deluge alarm valve from resetting.

## 3.2 Structural characteristics

### 3.2.1 Main components of deluge alarm valve

S/N	1	2	3	4	5
Components	Valve body	Valve cap	Diaphragm	Diaphragm Contraction	Bolts

### 3.2.2 Pipes and main components of deluge alarm valve

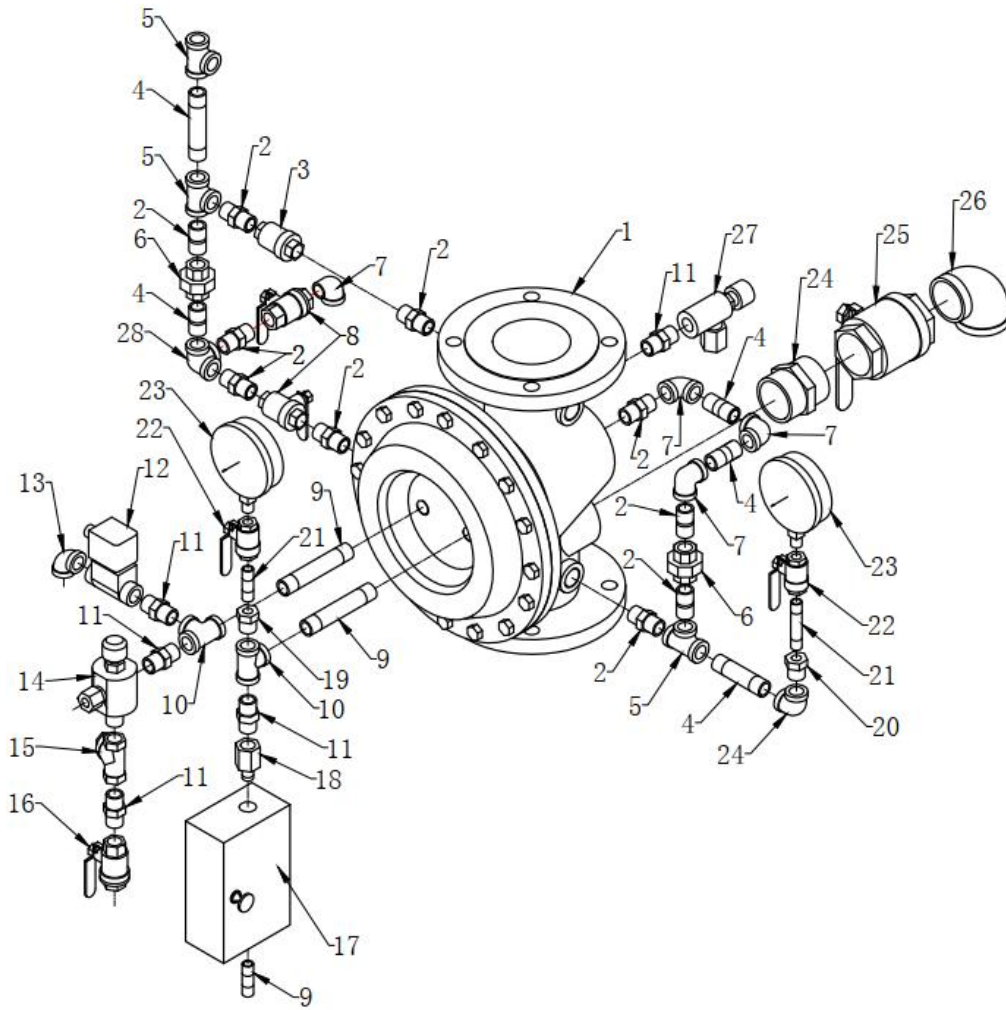

S/N	1	2	3	4	5	6
Components	Deluge valve	Butt joint	Check valve	Pipe fittings	Tee joint	Union
S/N	7	8	9	10	11	12
Components	90° Joint	Ball valve	Pipe fittings	Tee joint	Butt joint	Solenoid valve or pneumatic actuator
S/N	13	14	15	16	17	18
Components	90° Joint	Manual reset valve	Y type filter	Ball Valve	Emergency release valve bank	Release valve joint
S/N	19	20	21	22	23	24
Components	Joint	Joint	Pipe fittings	Ball Valve	Pressure gauge	Butt joint
S/N	25	26	27	28		
Components	Ball valve	90° Joint	Drip valve	Stereoscopic tee joint		

3.2.3 Pneumatic actuator (MODEL MHQD-1)

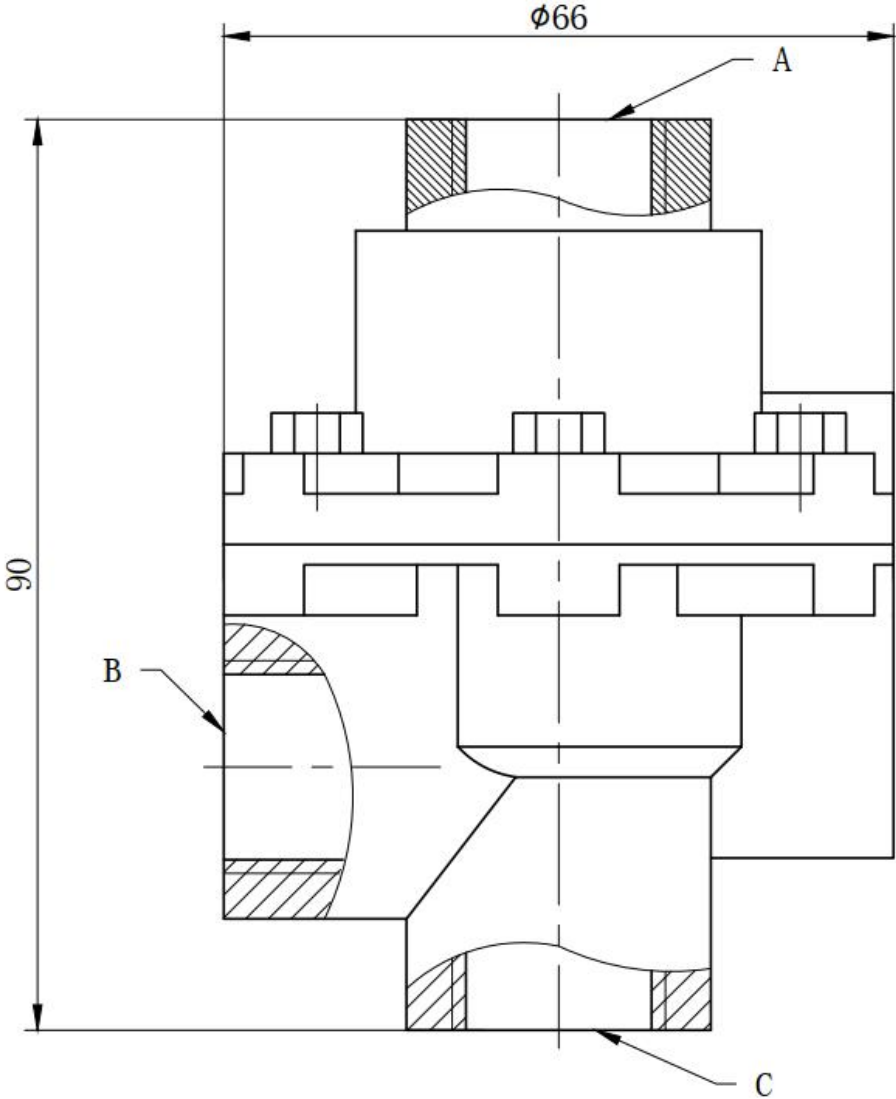

- A 1/2"NPT Pilot Line Connection (Air).
- B 1/2"NPT Inlet Connection from Deluge/Preaction Valve Differential Chamber.
- C 1/2"NPT Outlet Connection to Drain.

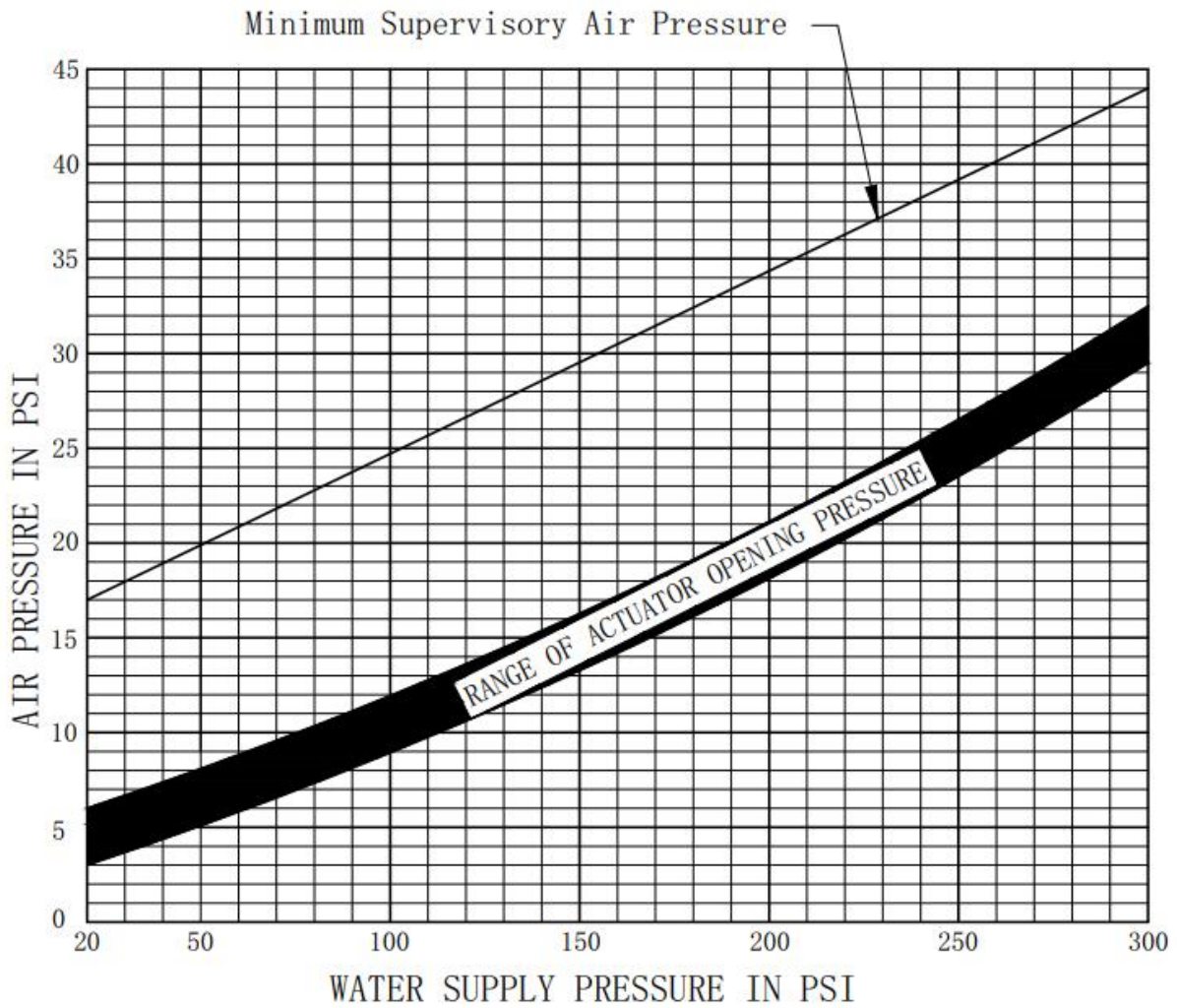

#### 4. Technical characteristics

4.1 Main technical parameters of deluge alarm valve are shown in the table below:

Nominal diameter (in/mm)	Rated pressure (PSI)	Adapter tube of alarm pipelines	Minimum operating pressure (PSI)	Minimum operating pressure is recommended (PSI)	Installation method
2/50	250/300	3/4 NPT	20	50	Vertically or horizontally mounted
2.5/65					
3/80					
4/100					
6/150					
8/200					

#### 4.2 Hydraulic Friction Loss Graph

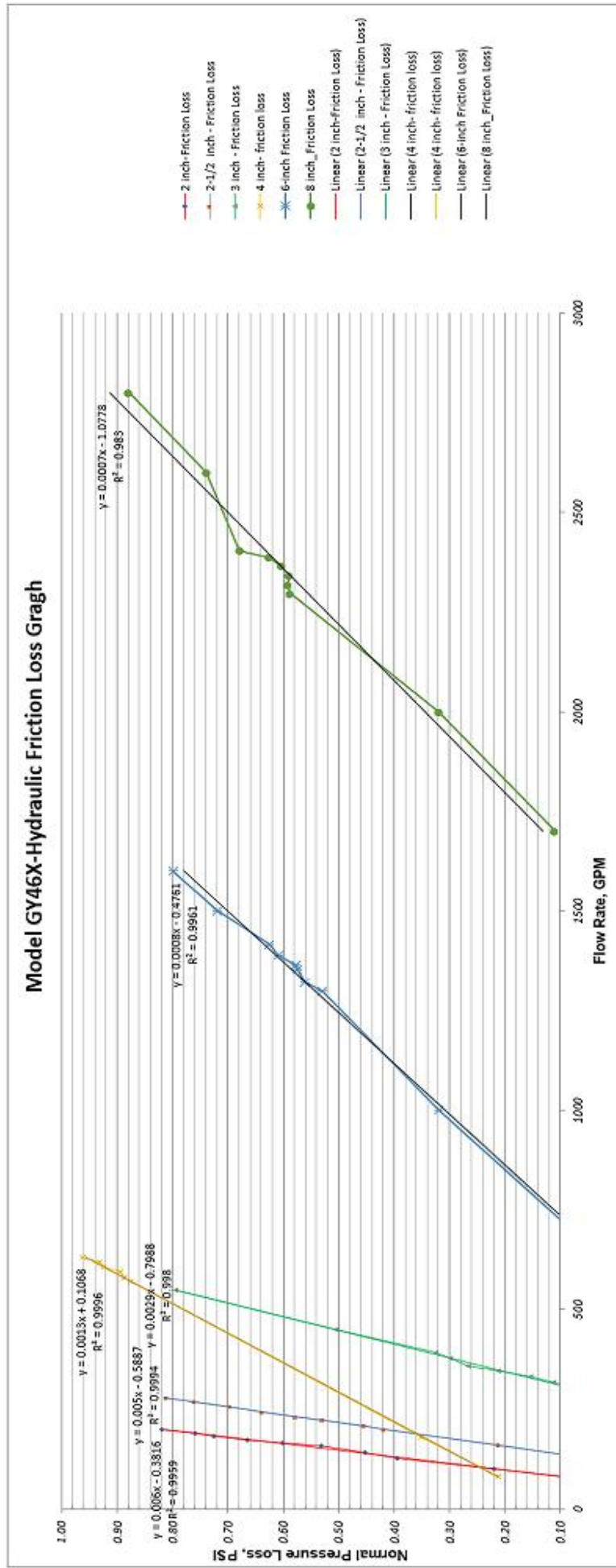

## 5. Size

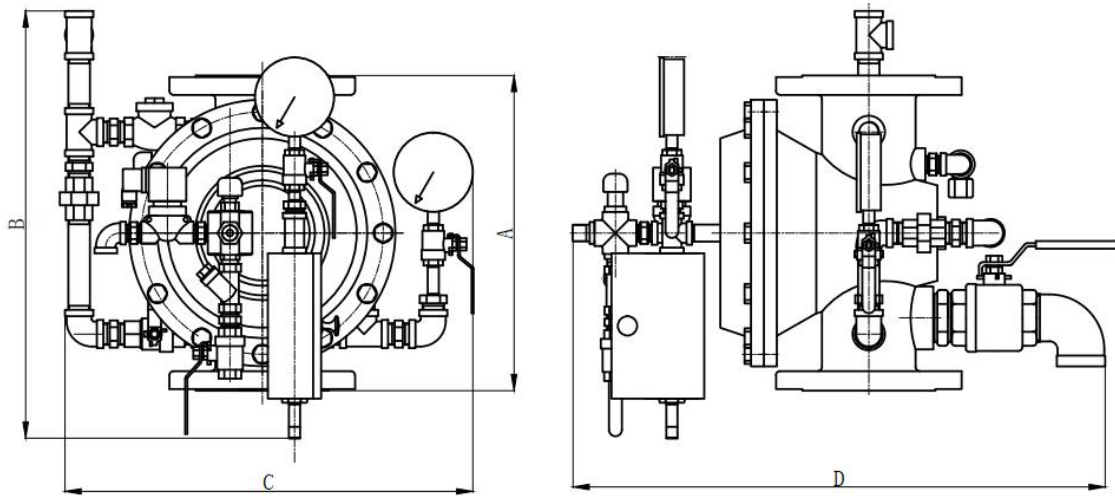

**Figure 3 Outline dimensional drawing of deluge alarm valve**

Diameter (in/mm)	A(mm)	B(mm)	C(mm)	D(mm)
2/50	287±2	440	460	500
2.5/65	287±2	440	460	540
3/80	340(324)±2	450	490	570
4/100	390(350)±2	520	490	680
6/150	508(460)±2	570	570	800
8/200	584(570)±2	650	650	900

## 6. Installation and Commissioning

**6.1** The deluge alarm valve bank shall be installed in a room with a temperature greater than 4°C and less than 70°C with drainage facilities. It shall be installed close to the protection target for easy operation to reduce the length of the water distribution pipeline and improve the system response time.

**6.2** The deluge alarm valve can be installed horizontally or vertically. But the installation of the solenoid valve shall always keep the solenoid core in a vertical position. The set air pressure of the pneumatic actuator shall not be lower than the recommended minimum system air pressure (3.2.3). Service clearance shall be reserved in four directions, with the distance to the ground of 1.2m, the distance from both sides to the wall not less than 0.5m,

and the distance from the front to the wall not less than 1.2m.

**6.3** The water supply control valve in front of the alarm valve and control valve behind the alarm valve shall be installed for convenience of repair and commissioning.

**6.4** The valve body shall be installed as per the water flow direction indicated by arrows. Before installation, pipes shall be rinsed till the water becomes clear, in order to avoid the sealing performance of the valve from being affected by the deposited sediment or sewage.

**6.5** Water motor alarm bell shall be installed on the outer walls of common aisle or near the duty room, and the steel pipe connecting the alarm bell to the deluge alarm valve shall not be greater than 20m in length.

**6.6** The deluge alarm valve system shall be commissioned upon installed:

**6.6.1** The commissioning shall be conducted after the water pump, pipe network, control circuit, etc. are all installed in accordance with the construction specifications and the pipelines have passed the strength and tightness tests.

**6.6.2** Switch off the water supply control valve in front of the alarm valve and the ball valve on the water injection loop.

**6.6.3** Switch on the drain valve (switch off the auxiliary drain valve on the system, if any) to drain all the residual water in the system.

**6.6.4** Push the reset button of the drip valve at least twice; the water has been drained when the water flow is small or stops.

**6.6.5** Switch off all drain valves and the emergency manual release valve, and make sure the solenoid valve or pneumatic actuator is off and the ball valve on the alarm test loop is off.

**6.6.6** Switch on the ball valve on the water injection loop, and slowly press the reset valve reset button. In this process, it is normal for the reset valve to have water flowing out of the drain hole, and the water flow will stop when the pressure in the diaphragm chamber increases. Release the reset button when the indication values on the water supply pressure gauge and the diaphragm chamber pressure gauge are the same. Then completely switch on the water supply control valve in front of the alarm valve. The system enters the ready condition.

**6.6.7** Make sure the alarm system is switched on when the deluge alarm valve bank is in a ready condition.

**6.6.8** After the primary actuation of the deluge alarm valve bank, reset it following steps 6.6.2

through 6.6.7.

## 7. Usage and operation

**7.1** The system can only be put into use after passing the acceptance. When the deluge alarm valve bank is in the ready condition, the water supply control valve in front of the alarm valve and the control valve behind the alarm valve should be completely switched on, and the control valve on the alarm system shall be hung with a normally open sign.

**7.2** According to the usage, an alarm system test should be carried out regularly. The purpose is to check the system conditions so that it always maintains normal conditions. By switching on the ball valve on the alarm test loop, the water motor alarm bell shall start to alarm continuously, the pressure switch is actuated, and the electrical contact is connected; otherwise, check the alarm pipeline and the water inlet of the water motor alarm bell for clogging by sand, rust, and dirt. Any clogging found should be removed in time. Any damaged, invalid, inaccurate and insensitive parts or instruments, if any, should be replaced immediately.

## 8. Fault Analysis and Troubleshooting

Faults	Reason analysis	Troubleshooting
Water still flows out from the drip valve when the deluge alarm valve group is in the ready condition.	Diaphragm damage	Switch off the water supply control valve in front of the alarm valve, the control valve behind the alarm valve and the ball valve on the water injection loop, switch on the emergency release valve, and disassemble the valve cap to check whether the diaphragm is damaged or foreign matters.
Water constantly flows out of the drain pipe of the reset valve	There are foreign matters in the reset valve or the internal sealing ball is	Remove the joint on the reset valve connecting to the drain pipe, clean up foreign matters or replace the sealing ball. Notes: The sealing ball in the reset valve is easy to drop.

	damaged	
Too long reset time	Filter in the water injection loop is blocked	Switch off the water supply control valve in front of the alarm valve and the ball valve on the water injection loop, remove and clean the filter screen of the filter.
The external water motor alarm does not work, or the alarm sound is not loud enough	The alarm inlet is blocked or the bell clapper mechanism is jammed	Remove the alarm bell, wash the water inlet pipe, or reassemble the impeller and hammer assembly of the water motor alarm bell to make the impeller rotate flexibly

## 9. Safety Protection Device and Trouble Removal

**9.1** The product may be damaged due to improper installation, use, and maintenance. Please check the product and its components frequently for signs of damage, loss or danger. The product can be used again only after the inspection and repair by authorized maintenance personnel, if necessary.

**9.2** Don't use the product if any problems are found in the product and its components, and contact the company's service department in time to learn how to implement and inspect the product according to the standards, and send the product for repair if necessary.

**9.3** The valve body shall be installed as per the water flow direction indicated by arrows. If leakage or other failures occur in the valve bank during use, overhaul and troubleshooting shall be conducted in time in accordance with relevant methods specified in the table in Chapter 8 of this manual. In case of unknown failure causes, please contact with us. If the system losses the fire-extinguishing function because the ready condition of the system is interrupted due to repair, maintenance or other reasons, relevant personnel and departments must be notified in advance to take preventive measures, and firefighting personnel should be assigned to be on duty.

## 10. Maintenance and Repair

### 10.1 System periodic tes

Alarm test, switch function test and other tests should be carried out regularly after the system is installed. After the test, open the drain valve of the alarm system, and close the valve after the water draining out from the valve group.

#### 10.1.1 Alarm test

The test is recommended to be conducted once a month (the frequency can be set based on factors such as fire rating and use environment). The test shall be conducted according to the following procedures:

a: Switch on the ball valve on the alarm test loop when the valve group is in the ready condition to make the water motor alarm bell or pressure switch actuate and alarm.

b: Confirm that the alarm system is normal, switch off the ball valve on the alarm test loop to stop the alarm.

#### 10.1.2 Manual switch function test

The test is recommended to be conducted once every quarter (the frequency can be set based on factors such as fire resistance and use environment) in the warm climate. Before the test, drainage measures should be taken near the valve bank, and the alarm valve bank is in a ready condition. The test should be conducted according to the following procedures:

a: Notify relevant personnel and departments.

b: Switch off the control valve behind the alarm valve.

c: Manually switch on the ball valve of the emergency release valve, and the readings on the pressure gauge in the diaphragm chamber decrease.

d: Press the reset button of the drip valve, sufficient water flows out of the drain loop or the alarm system alarms, proving the successful actuation of the deluge alarm valve.

e: Complete the reset following steps 6.6.2 through 6.6.7, and switch on the control valve behind the alarm valve. The manual switch function test is completed.

### 10.1.3 Remote switch function test

The test is recommended to be conducted once every quarter (the frequency can be set based on factors such as fire resistance and use environment) in the warm climate. Before the test, drainage measures should be taken near the valve bank, and the alarm valve bank is in a ready condition. The test should be conducted according to the following procedures:

a: Notify relevant personnel and departments.

b: Switch off the control valve behind the alarm valve .

c: Simulate a fire, and actuate a detector, so that the solenoid valve or pneumatic actuator is switched on, and the readings on the pressure gauge in the diaphragm chamber drop.

d: Press the reset button of the drip valve, Sufficient water flows out of the drain loop or the alarm system alarms, proving the successful actuation of the deluge alarm valve.

e: Complete the reset following steps 6.6.2 through 6.6.7, and switch on the control valve behind the alarm valve. The remote switch function test is completed.

## 10.2 System periodic maintenance

The deluge alarm valve should be maintained and repaired regularly, and the maintenance and repair shall be conducted when the valve is disabled. The operating steps are shown as below:

a: Switch off the water supply control valve in front of the alarm valve and the control valve behind the alarm valve, and switch off the ball valve on the water injection loop.

b: Switch on the drain valve and emergency release valve of the deluge alarm valve.

Maintenance and repair can be conducted at this time.

### 10.2.1 Diaphragm chamber

a: Disassemble pipes connecting to the valve cap, remove bolts on the valve cap, and remove the valve cap. Notes: Do not remove valve cap when there is pressure in the diaphragm chamber.

b: Check the diaphragm. slight deformation is normal, but the diaphragm needs to be

replaced immediately in case of large deformation, bulging, cracks, etc.

c: After the inspection, reinstall the valve cap and tighten the bolts to ensure the good sealing.

Replace the diaphragm accessories, refer to Figure 1

### **10.2.2 Reset valve examination**

a: Check the reset valve during the tests specified in 10.1.2 and 10.1.3. When performing the reset operation in 6.6.6, replace the reset valve if the diaphragm chamber cannot be injected with water. If the reset valve cannot be replaced, please contact the company in time for repair by professionals under the guidance of the company's technical department. It is strictly forbidden to disassemble the alarm valve randomly.

b: For other problems, refer to the related methods specified in the table in Chapter 8 for maintenance and troubleshooting.

### **10.2.3 Drip valve examination**

Remove the drip valve to check whether there is any foreign matter and whether the push rod is flexible. Clean the foreign matters, if any. Note that the ball sealer in the drip valve is easy to fall off.

### **10.2.4 Pressure gauge examination**

The accuracy of the pressure gauge should be calibrated. It should be replaced if damaged.

### **10.2.5 Filter and pipeline inspection**

Clean the filter ,check pipelines and pipe joints for leakage .

## **10.3 Specific Record**

Each inspection, maintenance, and repair work should be recorded with a special record sheet for future reference.

Note: The parts and components should be maintained by experienced personnel.

Warning: During the maintenance period, the system has been out of service, so temporary fire prevention measures must be taken.

## **11. Transportation and Storage**

**11.1** The deluge alarm valve is separately fixed in the packing box.

**11.2** The deluge alarm valve should be subject to waterproof and vibration damping measures during transportation, and the anti-collision measures during loading and unloading.

**11.3** The deluge alarm valve shall be stored in ventilated and dry warehouses to avoid storage with corrosive substances under the temperature of  $-10^{\circ}\text{C}\sim+40^{\circ}\text{C}$ .

## **12. Unpacking and Check**

Unwrap the packing, check the packing list carefully, and check the flange joints and pipelines of the deluge alarm valve for damages. If damages are found, the parts shall be replaced and troubleshot in time.

## **13. Environmental Protection and Others**

Sticking to the cause of public safety, we value customer safety and environmental protection. We carry out research and development, manufacturing, operation, service and other related activities following the operational control procedures of our management system, with a purpose of providing customers with safe, reliable, and low-carbon products.

### **13.1 Important safety information**

The improper installation and usage of fire-fighting equipment and its components may cause potential safety hazards, and may cause personal injuries or property losses. In order to reduce these hazards, please strictly follow the relevant national standards and specifications in terms of installation, use, operation, and maintenance, and follow all the reminding information on the manual and the product.

The product may be damaged due to improper installation, use, and maintenance. Please check the product and its components frequently for signs of damage, loss or danger. The product can be used again only after the inspection and repair by authorized maintenance personnel, if necessary.

Don't use the product if you have any doubts on the product and its components, and contact the company's service department in time to learn how to implement and inspect the product according to the standards, and send the product for repair if necessary.

## **13.2 Environmental control**

Ningjin APC Industries Co., Ltd. attaches great importance to the protection of the global environment and advocates the energy saving, emission-reducing, and low-carbon life. It maintains a healthy and sustainable interaction with the nature, and promises to undertake its environmental responsibilities. We have adopted appropriate disposal procedures during product design and development, manufacturing and processing, sales and services to constantly reduce the impact of products on the environment and comply with relevant laws and regulations.

After the service life expires, the products should be recycled and reused in accordance with applicable recycling regulations to minimize the potential impact of any hazardous substances on the environment and the human health.

If you have any doubts about the disposal of the products, please contact our service department to learn about relevant laws, regulations and disposal procedures. It can be reported to the local environmental protection authority when necessary.